

City Pump

Mobile, Versatile & Affordable Truck-Mounted Concrete Pump

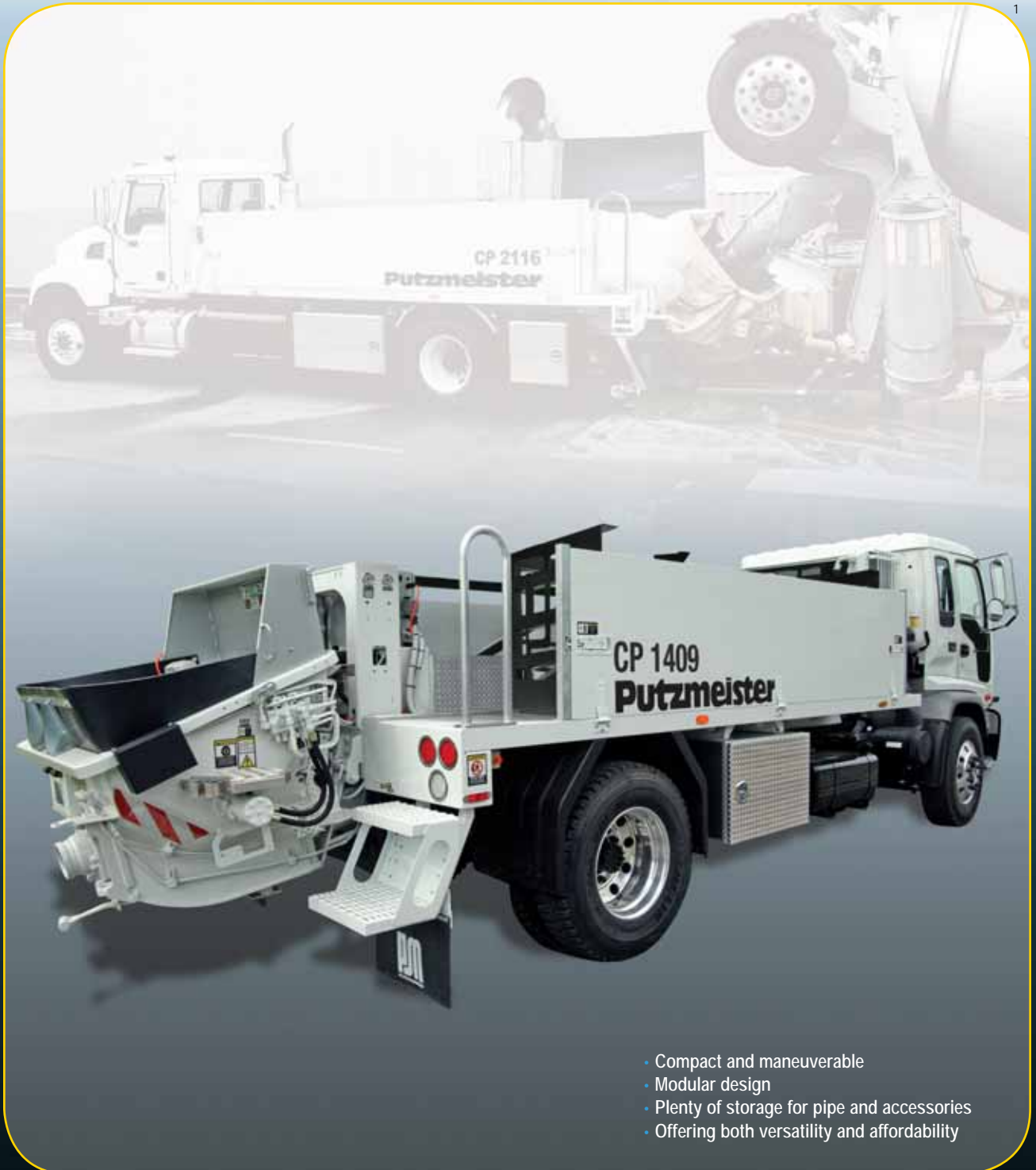

City Pump

- Compact and maneuverable
- Modular design
- Plenty of storage for pipe and accessories
- Offering both versatility and affordability

Putzmeister's Versatile City Pump

Unsurpassed Performance and Mobility are Not an Urban Myth

Convenient Accessory Storage

With the deck-mounted side pipe rack and large fold up side panels now standard, the City Pump allows for plenty of space and provides a quick, convenient and clean way to store everything that's required for your operation. Racks accommodate 10' (3m) of pipe.



Deck-mounted pipe racks shown with optional overhead pipe rack



Bolt-on modular flatpack

Exclusive Modular Flatpack and Free Flow Hydraulics

Fully removable, Putzmeister's modular bolt-on flatpack and hydraulic system combine versatility and servicing convenience. The simple design allows for cost-effective, minimally labor intensive pump cell replacement upgrades, repairs or as part of a maintenance program. Smooth and efficient pumping are hallmarks of Putzmeister's free flow hydraulics. Performing to a higher standard at a lower cost than other pumps, this unique hydraulic system features a closed oil circuit that produces greater output with less energy consumption. The reduction of pressure peaks and surges means that a Putzmeister City Pump runs smoother, faster and more fuel-efficiently than competitive models.

The Reliable S-Valve – A Proven Technology

Ideal for high-pressure applications, Putzmeister's S-Valve is capable of pumping harsh concrete mixes. Its 8" to 6" (200 to 150mm) gradual reduction provides a smoother concrete flow, while the valve's "thick-walled" construction increases its life span and reduces operating costs.



Large capacity hopper and breakaway rear steps

Large Capacity Hopper

The large capacity hopper has a 19.4 cu ft (550L) capacity with a standard heavy-duty hydraulic remixer/agitator to gulp down the toughest mixes job after job.

Options

- Hydraulically activated rear outriggers
- Heavy-duty angled overhead pipe rack
- Multi-function wireless remote control
- Automatic lubrication system with timer

Consult factory for other available options not listed above.



Putzmeister's innovative City Pump makes navigating congested job sites and busy streets a walk in the park.

This maneuverable truck-mounted unit offers greater mobility than a trailer pump and is more affordable than a large boom pump. Handling the harshest of mixes, the large capacity hopper and powerful S-Valve are a reliable combination job after job. With compact dimensions and plenty of storage space for the pipe system and accessories, setup is fast and easy.

In addition to convenience, the versatile City Pump opens up new opportunities for long distance pump applications – both indoors and out.

Standard Features

- Pump: PTO-driven through distribution gearbox
- Modular design
- Exclusive free flow hydraulics
- Deck-mounted pipe racks and fold-down side panels
- Variable displacement axial piston pump
- Variable volume (0 to full) pump output
- Hydraulic oil cooler
- Multi-piece piston cup design
- Hard-chromed material cylinders
- Proven reliable S-Valve
- RS 905A hopper with 19.4 cu ft (550L) capacity for CP 1409H
- RS 907A hopper with 19.4 cu ft (550L) capacity for CP 2112L and CP 2116H
- Manual stroke change switch
- Hydraulic remixer/agitator
- Hopper grate with electric vibrator
- Splash guards
- Manual grease system at hopper
- High pressure water system with pump, tank and hose
- 175 gallon (660L) water tank
- Fully-enclosed weatherproof control panel
- Emergency stop button
- Convenient stroke change switch
- Electric stroke counter
- Remote control with 130 ft (40m) cable
- Breakaway rear steps
- Toolboxes and tool tray
- High quality paint finish
- Ship-away kit with replacement filters

Specifications

Truck-Mounted City Pump

City Pump

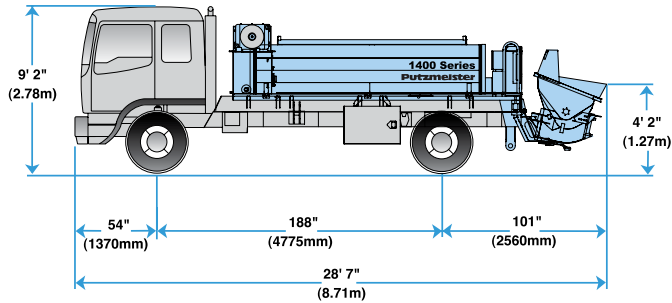

CP 1409H Truck-Mounted Specifications

Based on Model GMC TT7500

| | | |
|----------------------|------------|-----------|
| Length | 28' 7" | (8.71m) |
| Width | 8' 2" | (2.50m) |
| Height | 9' 2" | (2.78m) |
| Wheelbase | 188" | (4,775mm) |
| Front axle weight | 8,134 lbs | (3,689kg) |
| Rear axle weight | 12,721 lbs | (5,770kg) |
| Approx. total weight | 20,855 lbs | (9,460kg) |

Power

| | |
|--------------------|---|
| Truck engine | 250 hp @ 2200 rpm |
| Pump | PTO-driven through distribution gearbox |
| Fuel tank capacity | 2 x 50 gallons (2 x 190L) |

Weights are approximate and include pump, truck, full hydraulic oil, driver and some fuel. Dimensions will vary with different truck makes, models and specifications.

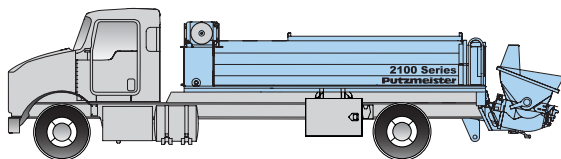

CP 2112L & CP 2116H Truck-Mounted Concrete Pumps

Please consult factory for dimensions and specifications on this model.

Pump Specifications

| | 1409H | 2112L | 2116H |
|--------------------------------|--|---|---|
| Output — rod side | 117 yd ³ /hr (90m ³ /hr) | 142 yd ³ /hr (109m ³ /hr) | 210 yd ³ /hr (160m ³ /hr) |
| | piston side | 78 yd ³ /hr (60m ³ /hr) | 85 yd ³ /hr (65m ³ /hr) |
| Pressure — rod side | 1015 psi (70 bar) | 1015 psi (70 bar) | 1233 psi (85 bar) |
| | piston side | 1537 psi (106 bar)* | 1624 psi (112 bar)* |
| Horizontal pumping distance* — | | | |
| rod side | 1500' (457m) | CF** | CF** |
| piston side | 2000' (610m) | CF** | CF** |
| Vertical pumping distance* — | | | |
| rod side | 540' (165m) | CF** | CF** |
| piston side | 750' (229m) | CF** | CF** |
| Material cylinder diameter | 8" (200mm) | 9" (230mm) | 9" (230mm) |
| Stroke length | 55" (1400mm) | 83" (2100mm) | 83" (2100mm) |
| Maximum strokes per minute — | | | |
| rod side | 36 | 21 | 31 |
| piston side | 25 | 13 | 21 |
| Volume control | 0-Full | 0-Full | 0-Full |
| Vibrator | Standard | Standard | Standard |
| Hard-chromed material cylinder | Standard | Standard | Standard |
| Hydraulic system | Free Flow | Free Flow | Free Flow |
| Hydraulic system pressure | 5075 psi (350 bar) | 5075 psi (350 bar) | 5075 psi (350 bar) |
| Differential cylinder diameter | 4.3" (110mm) | 5.1" (130mm) | 5.5" (140mm) |
| Rod diameter | 2.5" (63mm) | 3.1" (80mm) | 3.1" (80mm) |
| Maximum size aggregate | 2.5" (63mm) | 2.5" (63mm) | 2.5" (63mm) |
| Water tank | 172 gal (650L) | 185 gal (700L) | 185 gal (700L) |

Valve & Hopper

| S-Valve type (heavy duty cast) | 2018 | 2318 | 2318 |
|--------------------------------|-------------------------|-------------------------|-------------------------|
| Reduction | 8" to 6" (200 to 150mm) | 8" to 6" (200 to 150mm) | 8" to 6" (200 to 150mm) |
| Hopper capacity | 19.4 cu ft (550L) | 19.4 cu ft (550L) | 19.4 cu ft (550L) |
| Hopper height | 50" (1270mm) | 49" (1250mm) | 49" (1250mm) |

Maximum theoretical values listed.

Note: Maximum output and pressure cannot be achieved simultaneously.

* Standard delivery line system rated at max line pressure of 1233 psi (85 bar)

* 6" slump, 125mm delivery pipe, 70 yd³/hr end of line output.

** Consult factory for model specifications.

Photographs represented in this brochure are for informational purposes only and may depict optional or additional equipment not offered as standard.

Always refer to the appropriate owners manual for safe and proper operation of Putzmeister equipment.



Putzmeister America, Inc.
1733 90th Street
Sturtevant, WI 53177 USA
Telephone (262) 886-3200
(800) 884-7210
Facsimile (262) 884-6338
www.putzmeister.com



Authorized Distributor

Putzmeister's Versatile City Pump

Unsurpassed Performance and Mobility are Not an Urban Myth

Convenient Accessory Storage

With the deck-mounted side pipe rack and large fold up side panels now standard, the City Pump allows for plenty of space and provides a quick, convenient and clean way to store everything that's required for your operation. Racks accommodate 10' (3m) of pipe.



Deck-mounted pipe racks shown with optional overhead pipe rack

Exclusive Modular Flatpack and Free Flow Hydraulics

Fully removable, Putzmeister's modular bolt-on flatpack and hydraulic system combine versatility and servicing convenience. The simple design allows for cost-effective, minimally labor intensive pump cell replacement upgrades, repairs or as part of a maintenance program. Smooth and efficient pumping are hallmarks of Putzmeister's free flow hydraulics. Performing to a higher standard at a lower cost than other pumps, this unique hydraulic system features a closed oil circuit that produces greater output with less energy consumption. The reduction of pressure peaks and surges means that a Putzmeister City Pump runs smoother, faster and more fuel-efficiently than competitive models.



Bolt-on modular flatpack

The Reliable S-Valve – A Proven Technology

Ideal for high-pressure applications, Putzmeister's S-Valve is capable of pumping harsh concrete mixes. Its 8" to 6" (200 to 150mm) gradual reduction provides a smoother concrete flow, while the valve's "thick-walled" construction increases its life span and reduces operating costs.



Large Capacity Hopper

The large capacity hopper has a 19.4 cu ft (550L) capacity with a standard heavy-duty hydraulic remixer/agitator to gulp down the toughest mixes job after job.

Options

- Hydraulically activated rear outriggers
- Heavy-duty angled overhead pipe rack
- Multi-function wireless remote control
- Automatic lubrication system with timer

Consult factory for other available options not listed above.



Large capacity hopper and breakaway rear steps



Putzmeister's innovative City Pump makes navigating congested job sites and busy streets a walk in the park.

This maneuverable truck-mounted unit offers greater mobility than a trailer pump and is more affordable than a large boom pump. Handling the harshest of mixes, the large capacity hopper and powerful S-Valve are a reliable combination job after job. With compact dimensions and plenty of storage space for the pipe system and accessories, setup is fast and easy.

In addition to convenience, the versatile City Pump opens up new opportunities for long distance pump applications – both indoors and out.

Standard Features

- Pump: PTO-driven through distribution gearbox
- Modular design
- Exclusive free flow hydraulics
- Deck-mounted pipe racks and fold-down side panels
- Variable displacement axial piston pump
- Variable volume (0 to full) pump output
- Hydraulic oil cooler
- Multi-piece piston cup design
- Hard-chromed material cylinders
- Proven reliable S-Valve
- RS 905A hopper with 19.4 cu ft (550L) capacity for CP 1409H
- RS 907A hopper with 19.4 cu ft (550L) capacity for CP 2112L and CP 2116H
- Manual stroke change switch
- Hydraulic remixer/agitator
- Hopper grate with electric vibrator
- Splash guards
- Manual grease system at hopper
- High pressure water system with pump, tank and hose
- 175 gallon (660L) water tank
- Fully-enclosed weatherproof control panel
- Emergency stop button
- Convenient stroke change switch
- Electric stroke counter
- Remote control with 130 ft (40m) cable
- Breakaway rear steps
- Toolboxes and tool tray
- High quality paint finish
- Ship-away kit with replacement filters